

2/2 and 3/2-way ball valve with pneumatic rotary actuator



Type 8805 can be combined with...



Type 6012/6014 P
Pilot valve

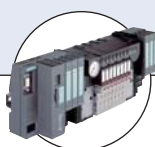

Type 8640/8644
Valve island

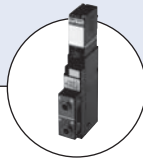

Type 5470
Solenoid valve



**Type 6518/6519
6519 NAMUR**
Solenoid valves



Type 8792/8793
Positioner

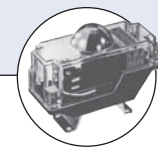

Type TEUXXX
Position feedback

- Pneumatic rotary actuator
- Stainless steel ball valve
- External regulation of the pistons
- Full bore
- Favourable flow rate

Bürkert's range of precision activated ball valves fulfil a wide variety of on-off process applications. Available in 2 or 3 way and both single acting and spring return they exhibit high flow rates by virtue of their reliable full bore design.

Control function A [SFA]

2/2- and 3/2-way valve, NC operation with Pilot valve

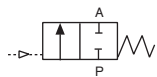

Control function B [SFB]

2/2- and 3/2-way valve, NO, operation with pilot valve

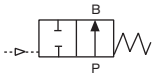

Control function I [SFI]

3/2 and 2/2 way valve with double-acting actuator, without spring, operation with pilot valve

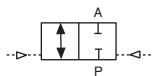

Technical data

Orifice	2/2-way ball valve 3/2-way ball valve	10 - 100 mm 10 - 40 mm
Body material	2/2-way ball valve 3/2-way ball valve	Stainless steel 1.4408 Stainless steel 1.4408
Actuator material		Aluminium
Ball material	2/2-way ball valve 3/2-way ball valve	Stainless steel 1.4401 Stainless steel 1.4401
Selector shaft material	2/2-way ball valve 3/2-way ball valve	Stainless steel 1.4401 Stainless steel 1.4401
Seal materials	Ball seal Actuating shaft seal	PTFE FKM
Pressure range		See ordering chart
Medium		Stainless steel body: aggressive fluids, which will not attack the body and seal
Medium temperature		-10 to +100 °C (see pressure temperature diagram)
Ambient temperature		-10 to +80 °C (see pressure temperature diagram)
Control medium		Compressed air, filtered, dry or oiled
Pilot pressure		6 to 8 bar ¹⁾
Port connection	2/2-way ball valve 3/2-way ball valve	G 1/4 - G 4 Thread acc. DIN EN 10226-1 (old DIN 2999) G 1/4 - G 2 Thread acc. DIN EN 10226-1 (old DIN 2999)
Installation		As required, preferably with actuator upright

¹⁾ Pressure values [bar]: Measured as overpressure with respect to the atmospheric pressure

2/2-way ball valve

Technical data

Orifice DN [mm]	Control function ¹⁾	Kv value water [m ³ /h] 2/3-pieces/compact flange ball valve	Nominal pressure** [bar]			Weight [kg]		
			StSt 2 pieces	StSt 3 pieces	StSt compact flange ball valve	StSt 2 pieces	StSt 3 pieces	StSt compact flange ball valve
10 / 12	A, B	9/13	100	63	--	1.5	1.85	--
	I	9/13	100	63	--	1.4	1.75	--
15	A, B	19	100	63	--	2.2	2.45	--
	I	19	100	63	--	1.5	1.75	--
20	A, B	46	100	63	40	4.0	2.7	3.8
	I	46	100	63	40	2.4	1.95	2.1
25	A, B	72	100	63	40	4.3	4.6	6.0
	I	72	100	63	40	2.6	2.3	4.4
32	A, B	105	100	63	40	5.9	5.25	7.7
	I	105	100	63	40	4.2	3.6	6.2
40	A, B	170	100	63	40	7.6	7.4	9.8
	I	170	100	63	40	5.9	4.6	8.1
50	A, B	275	100	63	40	13.4	9.1	12.8
	I	275	100	63	40	7.4	7.4	9.0
65	A, B	507	100	63	16	--	16.0	20
	I	507	100	63	16	--	13.2	14
80	A, B	905	100	63	16	--	25.1	26.3
	I	905	100	63	16	--	19.6	17.3
100	A, B	1414	100	63	16	--	35.2	29
	I	1414	100	63	16	--	28	21.8

¹⁾ A, B ... single-acting
I ... double-acting

** Operating pressure: see pressure temperature chart

Pressure temperature chart for stainless steel body

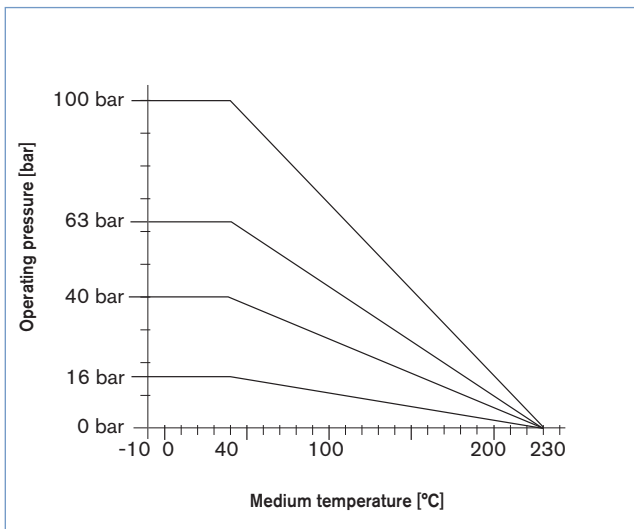

2/2-way ball valve, *continued*

Ordering chart for brass and stainless steel (StSt) (Minimum pilot pressure 6 bar)

Control function	Orifice DN [mm]	Port connection	Kv value water [m ³ //h]		Nominal pressure ²⁾ [bar]		Actuator		Item no.		
			StSt 2 pieces	StSt 3 pieces	StSt 2 pieces	StSt 3 pieces	StSt 2 pieces	StSt 3 pieces	StSt 3 pieces weld end port connection	StSt 2 pieces threaded port connection	StSt 3 pieces threaded port connection
A	10	G 1/4"	9	9	100	63	15	15	--	217 232	217 250
	12	G 3/8"	13	13	100	63	15	15	217 261	217 233	217 251
	15	G 1/2"	19	19	100	63	30	30	217 262	217 234	217 252
	20	G 3/4"	46	46	100	63	60	30	217 263	217 235	217 253
	25	G 1"	72	72	100	63	60	60	217 264	217 236	217 254
	32	G 1 1/4"	105	105	100	63	100	60	217 265	217 237	217 255
	40	G 1 1/2"	170	170	100	63	150	100	217 266	217 238	217 256
	50	G 2"	275	275	100	63	220	100	217 267	217 239	217 257
	65	G 2 1/2"	--	507	--	63	--	150	217 268	--	217 258
	80	G 3"	--	905	--	63	--	220	217 269	--	217 259
100	G 4"	--	1414	--	63	--	300	217 270	--	217 260	
B	10	G 1/4"	--	9	--	63	--	15	■	■	217 292
	12	G 3/8"	9	9	--	63	--	15	■	■	217 293
	15	G 1/2"	19	19	--	63	--	30	■	■	217 294
	20	G 3/4"	46	46	--	63	--	30	■	■	217 295
	25	G 1"	72	72	--	63	--	60	■	■	217 296
	32	G 1 1/4"	105	105	--	63	--	60	■	■	217 297
	40	G 1 1/2"	170	170	--	63	--	100	■	■	217 298
	50	G 2"	275	275	--	63	--	100	■	■	217 299
	65	G 2 1/2"	--	507	--	63	--	150	■	--	217 300
	80	G 3"	--	905	--	63	--	220	■	--	217 301
100	G 4"	--	1414	--	63	--	300	■	--	217 302	
I	10	G 1/4"	9	9	100	63	15	15	--	217 240	217 271
	12	G 3/8"	9	9	100	63	15	15	217 282	217 241	217 272
	15	G 1/2"	19	19	100	63	15	15	217 283	217 242	217 273
	20	G 3/4"	46	46	100	63	30	15	217 284	217 243	217 274
	25	G 1"	72	72	100	63	30	15	217 285	217 244	217 275
	32	G 1 1/4"	105	105	100	63	60	30	217 286	217 245	217 276
	40	G 1 1/2"	170	170	100	63	100	30	217 287	217 246	217 277
	50	G 2"	275	275	100	63	100	60	217 288	217 247	217 278
	65	G 2 1/2"	--	507	--	63	--	100	217 289	--	217 279
	80	G 3"	--	905	--	63	--	150	217 290	--	217 280
100	G 4"	--	1414	--	63	--	150	217 291	--	217 281	

¹⁾ Operating pressure, see pressure temperature chart

■ on request

i Further versions on request**>** Additional

Ball valves brass, nickel-plated
 Further connections and orifices
 Non standard fittings and versions

2/2-way compact flange ball valve

Ordering chart compact flange ball valve

Control function	Orifice [mm]	Kv value water [m ³ /h]	Nominal pressure * [bar]	Actuator	Weight [kg]	Item no.
A	20	46	40	30	3.8	217 306
	25	72	40	60	6.0	217 307
	32	105	40	60	7.7	217 308
	40	170	40	100	9.8	217 309
	50	275	40	150	12.8	217 310
	65	507	16	220	20	217 311
	80	905	16	300	26.3	217 312
	100	1414	16	300	29.0	217 313
I	20	46	40	15	2.1	217 314
	25	72	40	30	4.4	217 315
	32	105	40	30	6.2	217 316
	40	170	40	60	8.1	217 317
	50	275	40	60	9.0	217 318
	65	507	16	100	14.0	217 319
	80	905	16	100	17.3	217 320
	100	1414	16	150	21.8	217 321

* Operating pressure: see pressure temperature chart

**Switching position 0°/90°

3/2-way ball valve

Technical data

Stainless steel body

Orifice DN [mm]	Port connection	Kv value water [m ³ /h]	Nominal pressure * [bar]	Weight CFA [kg]	Weight CFI [kg]
10/12	G 1/4" / G 3/8	4.7 / 6.9*	63	2.55	-
				-	1.85
12	G 1/2"	6.9 / 11.2*	63	2.7	-
				-	2.0
15	G 3/4"	6.9 / 11.2*	63	4.3	-
				-	2.2
20	G 1"	18.9 / 29.2*	63	4.9	-
				-	3.4
25	G 1 1/4"	35.3 / 46.4	63	7.3	-
				-	5.75
32	G 1 1/2"	46.4 / 72.2*	63	8.3	-
				-	6.7
40	G 2"	83.4 / 135.9*	63	13.9	-
				-	11.5

* acc. to switch setting

3/2-way ball valve, *continued*

Pressure temperature chart for stainless steel

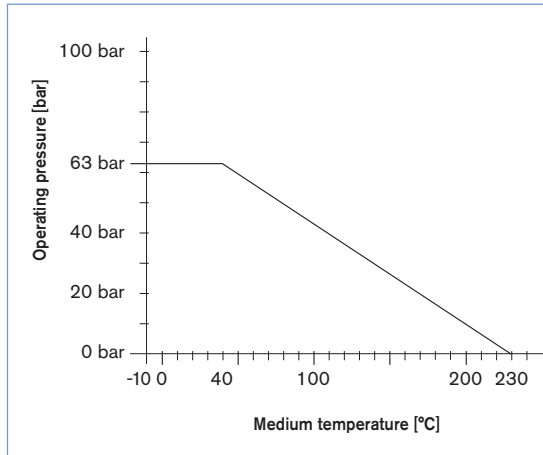

Switching position

Ball configuration	T			L
Position				
0°				
90°				
Switching position	T1	T2	T3	L4

Ordering chart, stainless steel

(reduced orifice) Minimum pilot pressure 6 bar, T2 and T3 on request

Switching position	Orifice [mm]	Port connection	Kv value water [m³/h]	Nominal pressure* [bar]	Actuator single-acting CFA	Item no. single-acting CFA	Actuator double-acting CFI	Item no. double-acting CFI	
0° 90°	T1	10	G 1/4"	4,7 / 6,9**	63	30	217 342	15	217 352
	12	G 3/8"	4,7 / 6,9**	63	30	217 343	15	217 353	
	12	G 1/2"	6,9 / 11,2**	63	30	217 344	15	217 354	
	15	G 3/4"	6,9 / 11,2**	63	60	217 345	15	217 355	
	20	G 1"	18,9 / 29,2**	63	60	217 346	30	217 356	
	25	G 1 1/4"	35,3 / 46,4**	63	100	217 347	60	217 357	
	32	G 1 1/2"	46,4 / 72,2**	63	100	217 348	60	217 358	
	40	G 2"	83,4 / 135,6**	63	150	217 349	100	217 359	
0° 90°	L4	10	G 1/4"	5,6	63	30	217 325	15	217 333
	12	G 3/8"	5,6	63	30	217 326	15	217 334	
	12	G 1/2"	9,5	63	30	217 327	15	217 335	
	15	G 3/4"	9,5	63	60	217 328	15	217 336	
	20	G 1"	25,8	63	60	217 329	30	217 337	
	25	G 1 1/4"	40,4	63	100	217 330	60	217 338	
	32	G 1 1/2"	60,2	63	100	217 331	60	217 339	
	40	G 2"	114,4	63	150	217 332	100	217 340	

* Operating pressure: see pressure temperature chart

**Switching position 0° / 90°

2/2-way ball valve, *continued*

Dimensions [mm]

stainless steel body, 2 pieces

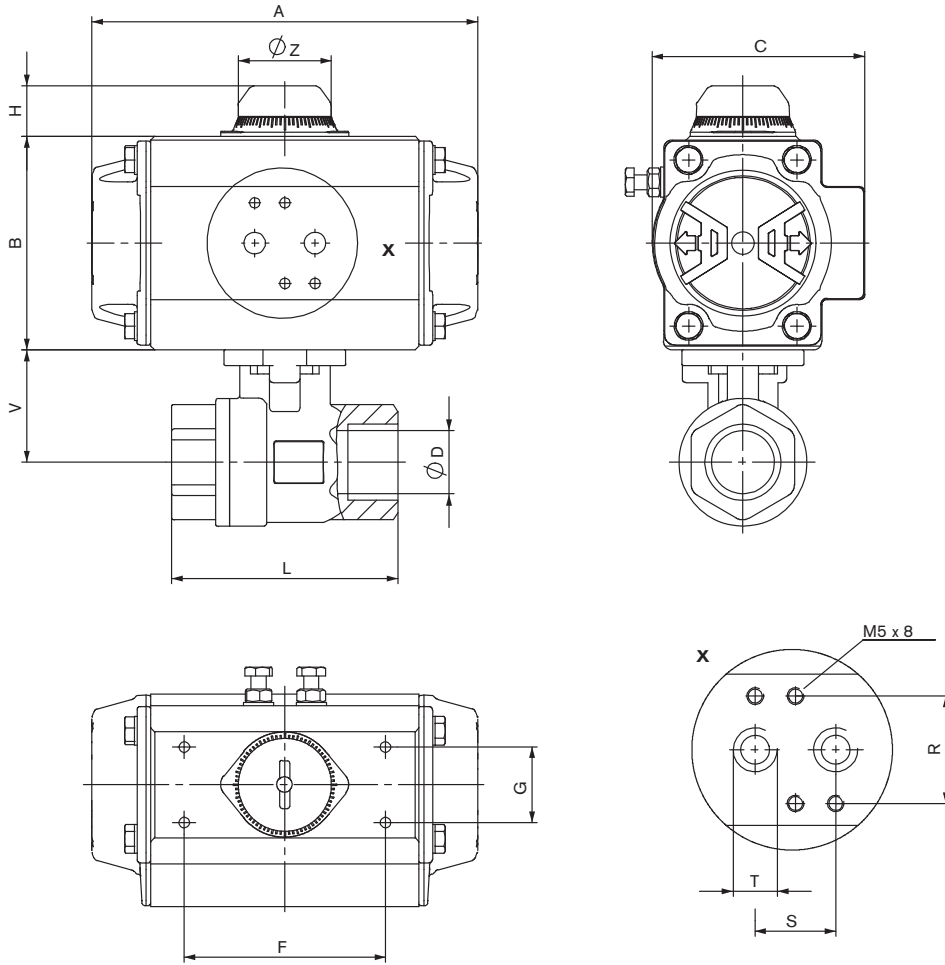

Orifice [mm]	Port Connection	Actuator	Weight [mm]										Valve size [mm]		
			A	B	C	F	G	H	R	S	T	ØZ	L	ØD	V
10	G 1/4	15	136	69	72	80	30	20	32	24	1/8	37	50	11.6	33.2
12	G 3/8	15	136	69	72	80	30	20	32	24	1/8	37	60	12.7	33.2
15	G 1/2	15	136	69	72	80	30	20	32	24	1/8	37	75	15	35
		30	153.5	85	84.5	80	30	20	32	24	1/8	37			
20	G 3/4	30	153.5	85	84.5	80	30	20	32	24	1/8	37	80	20	41
		60	203.5	102	93	80	30	20	32	24	1/8	37			
25	G 1	30	153.5	85	84.5	80	30	20	32	24	1/8	37	90	25	44.5
		60	203.5	102	93	80	30	20	32	24	1/8	37			
		100	241	115	106	80	30	20	32	24	1/8	37			
32	G 1 1/4	60	203.5	102	93	80	30	20	32	24	1/8	37	110	31.8	49.5
		100	241	115	106	80	30	20	32	24	1/8	37			
40	G 1 1/2	100	241	115	106	80	30	20	32	24	1/8	37	120	38	55
		150	259	127	118.5	80	30	20	32	24	1/4	37			
50	G 2	100	241	115	106	80	30	20	32	24	1/8	37	140	50.8	66.5
		220	304	145	136	80	30	20	32	24	1/4	37			

2/2-way ball valve, *continued*

Dimensions [mm]

Compact flange ball valve

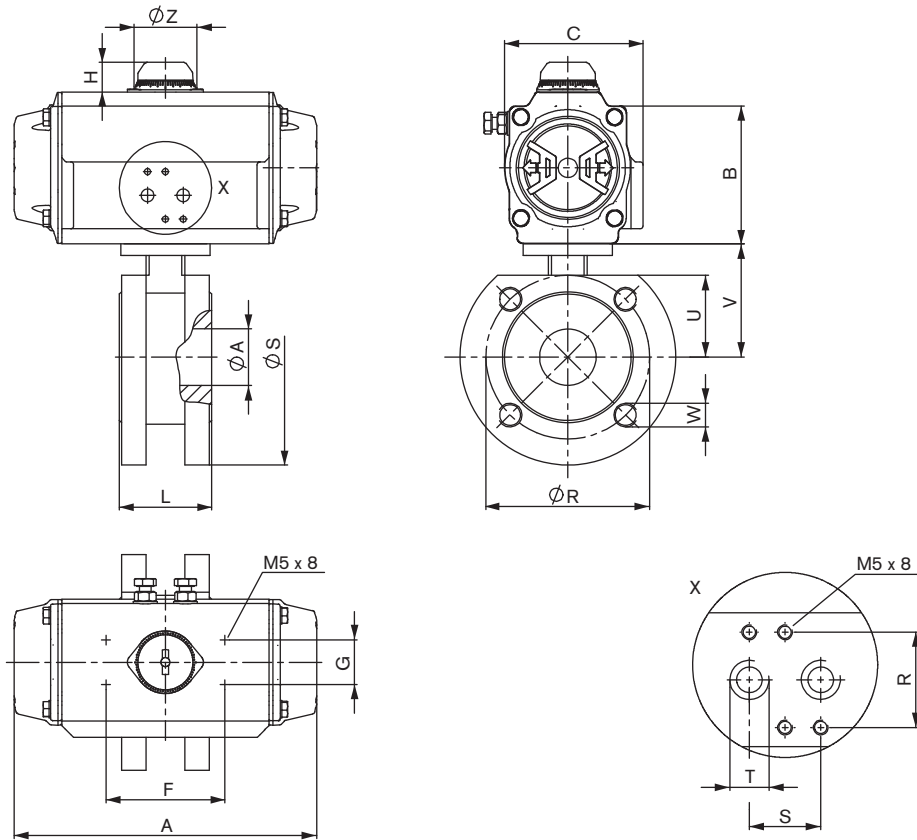

Orifice [mm]	Actuator	Weight [mm]										Valve size [mm]						
		A	B	C	F	G	H	R	S	T	ØZ	L	ØR	ØS	ØA	U	V	
20	15	140.5	69	59	80	30	20	32	24	1/8	42	44	75	105	20	38.5	64.3	M12x1.75
	30	158.5	85	72	80	30	20	32	24	1/8	42							
25	30	158.5	85	72	80	30	20	32	24	1/8	42	53	85	115	25	44.6	64.6	M12x1.75
	60	210.5	102	84.5	80	30	20	32	24	1/8	42							
32	30	158.5	85	72	80	30	20	32	24	1/8	42	58.4	100	135	32	51	69.0	M16x2
	60	210.5	102	84.5	80	30	20	32	24	1/8	42							
40	60	210.5	102	84.5	80	30	20	32	24	1/8	42	62	110	145	38	55	76.3	M16x2
	100	247.5	115	97.5	80	30	20	32	24	1/8	42							
50	60	210.5	102	84.5	80	30	20	32	24	1/8	42	78	125	155	50	63	85.7	M16x2
	150	268.5	127	111	80	30	20	32	24	1/4	42							
65	100	247.5	115	97.5	80	30	20	32	24	1/8	42	100	145	185	65	73.5	105	M16x2
	220	315	145	127	80	30	30	32	24	1/4	58							
80	100	247.5	115	97.5	80	30	20	32	24	1/8	42	120	160	200	76	94	123	M16x2
	300	345	157	136	80	30	30	32	24	1/4	42							
100	150	268.5	127	111	80	30	20	32	24	1/4	42	152	180	220	96	105	132	M16x2
	300	345	157	136	80	30	30	32	24	1/4	58							

2/2-way ball valve, *continued*

Dimensions [mm]

stainless steel body, 3 pieces
threaded ports

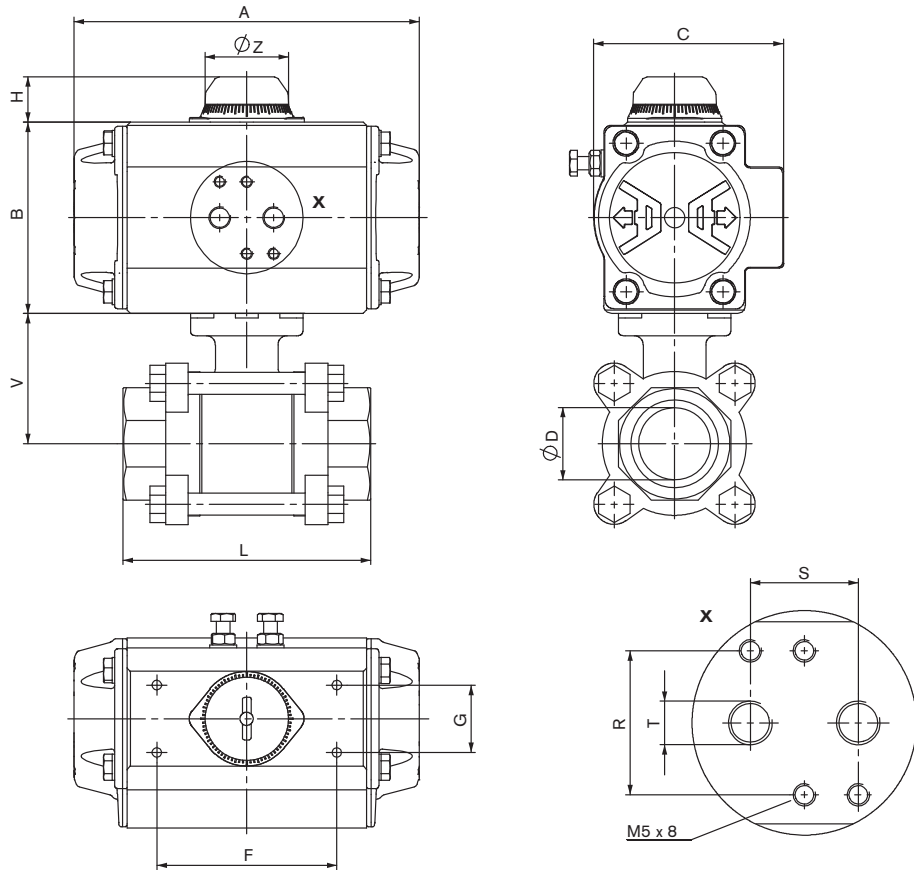

Orifice [mm]	Port Con- nection	Actua- tor	Weight [mm]										Valve size [mm]		
			A	B	C	F	G	H	R	S	T	ØZ	L	ØD	V
10	G 1/4	15	136	69	72	80	30	20	32	24	1/8	37	65	10	40
		30	153.5	85	84.5	80	30	20	32	24	1/8	37			
12	G 3/8	15	136	69	72	80	30	20	32	24	1/8	37	65	12	40
		30	153.5	85	84.5	80	30	20	32	24	1/8	37			
15	G 1/2	15	136	69	72	80	30	20	32	24	1/8	37	75	15	40
		30	153.5	85	84.5	80	30	20	32	24	1/8	37			
20	G 3/4	15	136	69	72	80	30	20	32	24	1/8	37	80	20	44
		30	153.5	85	84.5	80	30	20	32	24	1/8	37			
25	G 1	15	136	69	72	80	30	20	32	24	1/8	37	90	25	52
		60	203.5	102	93	80	30	20	32	24	1/8	37			
32	G 1 1/4	30	153.5	85	84.5	80	30	20	32	24	1/8	37	110	32	58
		60	203.5	102	93	80	30	20	32	24	1/8	37			
40	G 1 1/2	30	153.5	85	84.5	80	30	20	32	24	1/8	37	120	40	68
		100	241	115	106	80	30	20	32	24	1/8	37			
50	G 2	60	203.5	102	93	80	30	20	32	24	1/8	37	140	50	77
		100	241	115	106	80	30	20	32	24	1/8	37			
65	G 2 1/2	100	241	115	106	80	30	20	32	24	1/8	37	185	65	98
		150	259	127	118.5	80	30	20	32	24	1/4	37			
80	G 3	150	259	127	118.5	80	30	20	32	24	1/4	37	205	80	110
		220	304	145	136	80	30	30	32	24	1/4	51			
100	G 4	150	259	127	118.5	80	30	20	32	24	1/4	37	240	100	138
		300	333	157	146.5	80	30	30	32	24	1/4	51			

2/2-way ball valve, *continued*

Dimensions [mm]

stainless steel body, 3 pieces
Weld end

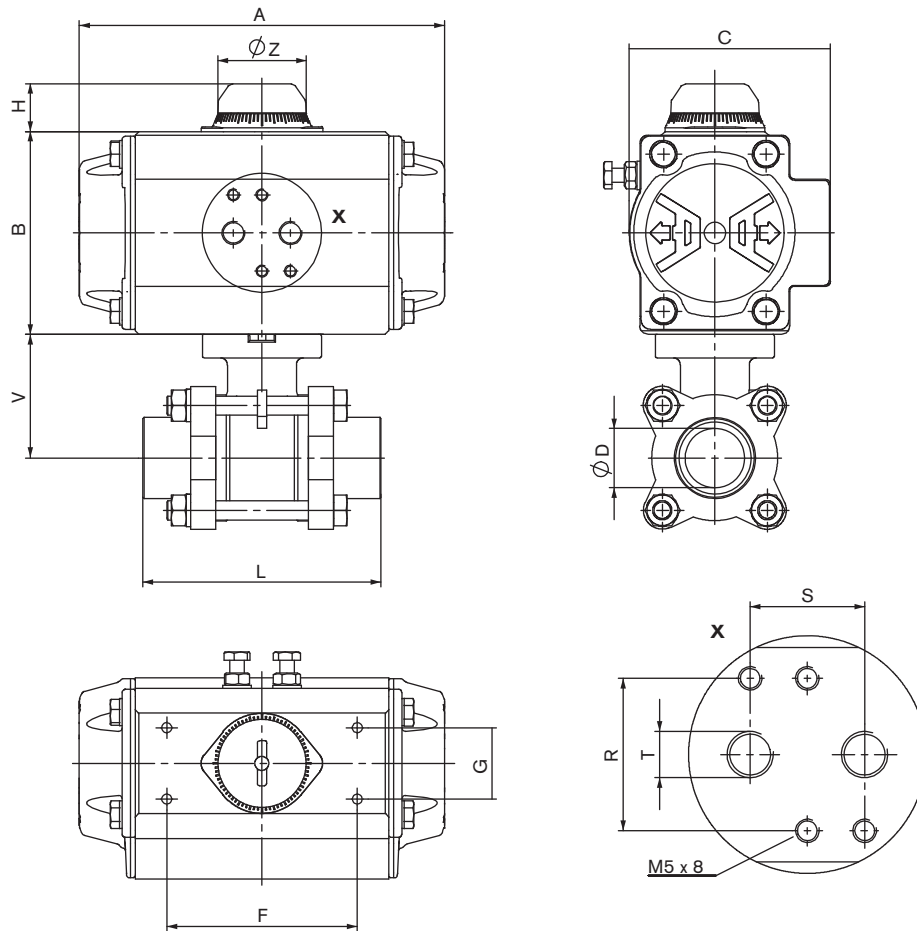

Orifice [mm]	Port Connection	Actuator	Weight [mm]										Valve size [mm]		
			A	B	C	F	G	H	R	S	T	ØZ	L	ØD	V
12	G 3/8	15	136	69	72	80	30	20	32	24	1/8	37	70	12	40
15	G 1/2	15	136	69	72	80	30	20	32	24	1/8	37	75	15	40
		30	153.5	85	84.5	80	30	20	32	24	1/8	37			
20	G 3/4	15	136	69	72	80	30	20	32	24	1/8	37	90	20	44
		30	153.5	85	84.5	80	30	20	32	24	1/8	37			
25	G 1	15	136	69	72	80	30	20	32	24	1/8	37	100	25	52
		60	203.5	102	93	80	30	20	32	24	1/8	37			
32	G 1 1/4	30	153.5	85	84.5	80	30	20	32	24	1/8	37	110	32	58
		60	203.5	102	93	80	30	20	32	24	1/8	37			
40	G 1 1/2	30	153.5	85	84.5	80	30	20	32	24	1/8	37	125	40	68
		100	241	115	106	80	30	20	32	24	1/8	37			
50	G 2	60	203.5	102	93	80	30	20	32	24	1/8	37	150	50	77
		100	241	115	106	80	30	20	32	24	1/8	37			
65	G 2 1/2	100	241	115	106	80	30	20	32	24	1/8	37	190	65	98
		150	259	127	118.5	80	30	20	32	24	1/4	37			
80	G 3	150	259	127	118.5	80	30	20	32	24	1/4	37	220	80	110
		220	304	145	136	80	30	30	32	24	1/4	51			
100	G 4	150	259	127	118.5	80	30	20	32	24	1/4	37	270	100	138
		300	333	157	146.5	80	30	30	32	24	1/4	51			

3/2-way ball valve, *continued*

Dimensions [mm]

stainless steel body

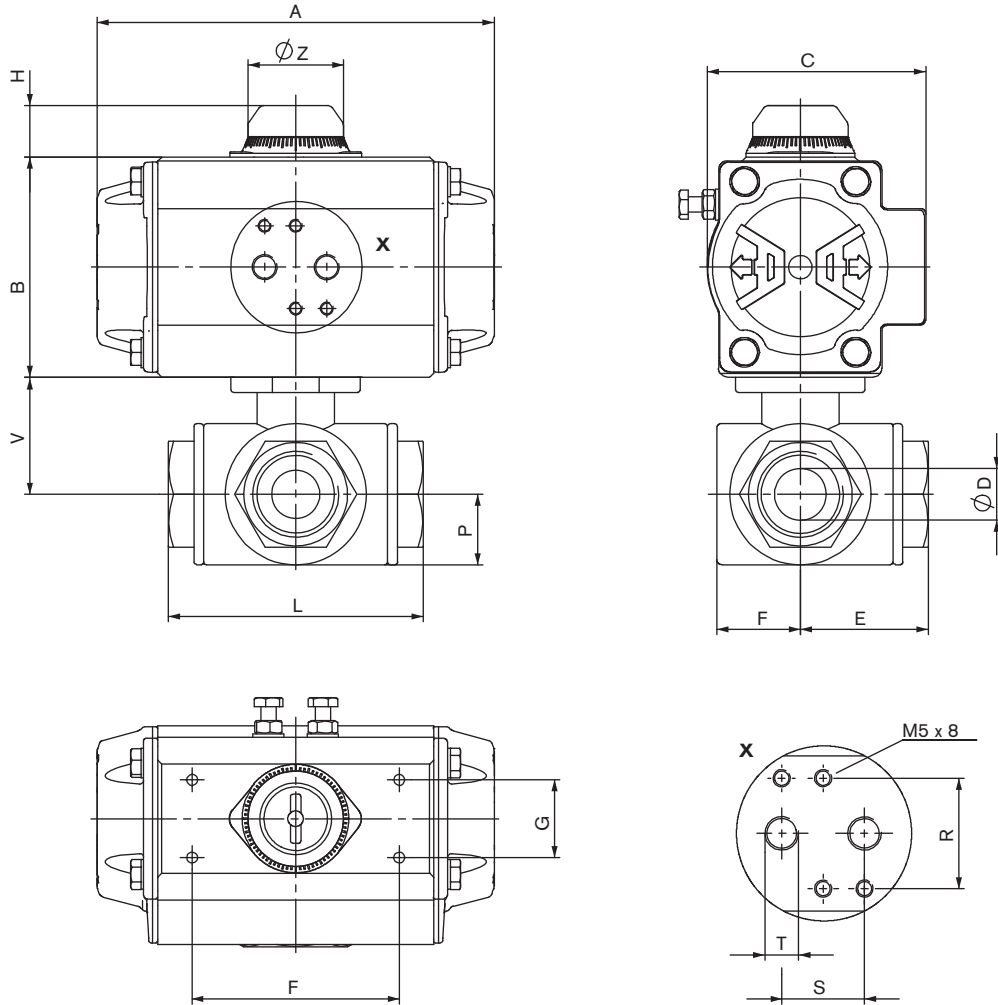

Orifice [mm]	Port Con- nection	Actua- tor	Weight [mm]										Valve size [mm]					
			A	B	C	F	G	H	R	S	T	ØZ	L	ØD	E	F	P	V
12	G 1/4	15	136	69	72	80	30	30	32	24	1/8	37	80	12	39.9	22	19.8	35.9
		30	153.5	85	84.5	80	30	20	32	24	1/8	37	80	12	39.9	22	19.8	35.9
12	G 3/8	15	136	69	72	80	30	20	32	24	1/8	37	80	12	39.9	22	19.8	35.9
		30	153.5	85	84.5	80	30	20	32	24	1/8	37	80	12	39.9	22	19.8	35.9
12	G 1/2	15	136	69	72	80	30	20	32	24	1/8	37	80	12	39.9	22	19.8	35.9
		30	153.5	85	84.5	80	30	20	32	24	1/8	37	80	12	39.9	22	19.8	35.9
15	G 3/4	15	136	69	72	80	30	20	32	24	1/8	37	87.5	15	43.7	23	32.2	42.1
		60	203.5	102	93	80	30	20	32	24	1/8	37	87.5	15	43.7	23	32.2	42.1
20	G 1	30	153.5	85	84.5	80	30	20	32	24	1/8	37	100	20	46.5	32.4	27.2	46.5
		60	203.5	102	93	80	30	20	32	24	1/8	37	100	20	46.5	32.4	27.2	46.5
25	G 1 1/4	60	203.5	102	93	80	30	20	32	24	1/8	37	123	25	52.1	38.3	34.2	52.1
		100	241	115	106	80	30	20	32	24	1/8	37	123	25	52.1	38.3	34.2	52.1
32	G 1 1/2	60	203.5	102	93	80	30	20	32	24	1/8	37	142.2	32	57.4	43	38.3	57.4
		100	241	115	106	80	30	20	32	24	1/8	37	142.2	32	57.4	43	38.3	57.4
40	G 2	100	241	115	106	80	30	20	32	24	1/8	37	170.6	40	66	56.2	49	66
		150	259	127	118.5	80	30	20	32	24	1/4	37	170.6	40	66	56.2	49	66

Ordering chart Accessories

5470 Namur*

(see also datasheet type 5470)

Circuit function	Orifice [mm]	Q_{n0} value air [l/min]	Pressure range [bar]	Power consumption (1 and 3 / 2 and 4)	Voltage/frequency [V/Hz]	Power consumption [W]	Item no.
C	4.0	300	2 - 10	G 1/8 (connections 1 and 3) Namur flange (conn. 2 and 4)	24/DC	2	136 761
					110-120/DC	3	136 762
					220-240/DC	3	136 763
				Push-in connection Ø 6mm (connections 1 and 3) Namur flange (Anschl. 2 and 4)	24/DC	2	136 764
					110-120/DC	3	136 765
					220-240/DC	3	136 766
G	4.0	300	2 - 10	G 1/8 (connections 1 and 3) Namur flange (Anschl. 2 and 4)	24/DC	2	136 767
					110-120/DC	3	136 768
					220-240/DC	3	136 769
				Push-in connection Ø 6mm (connections 1 and 3) Namur flange (conn. 2 and 4)	24/DC	2	136 770
					110-120/DC	3	136 771
					220-240/DC	3	136 772
				G 1/8 (connections 1 and 3) Namur flange with oneway flow restrictor (conn. 2 and 4)	24/DC	2	136 773
					110-120/DC	3	136 774
					220-240/DC	3	136 775

* Only recommended up to actuator size 220

Cable plug Type 2506 acc. to DIN 43650 Form C:

(see also datasheet type 2506)

Circuitry	Voltage	Type of current	Item no.
without circuitry (standard)	0 - 250 V	DC	008 353

6519 Namur

(see also datasheet type 6519)

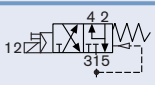
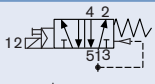
Circuit function	Orifice [mm]	Seal material body	Thread insert material ¹⁾	Port connection threaded port	Q_{n0} value air ²⁾ [l/min]	Pressure range ³⁾ [bar]	Weight [g]	Power consumption [W]	Voltage/frequency [V/Hz]	Item no.
 <p>3/2-way valve with exhaust recycling, in de-energized position port 2 fed back internally</p>	6.0	NBR and PUR	stainless steel	G 1/4	900	2 - 8	460	2	24/DC	131 425
									24/50-60	131 426
									110/50-60	131 427
									230/50-60	131 428
 <p>5/2-way valve, servo-assisted, in de-energized position pressure port 1 connected to port 2, output 4 exhausted</p>	6.0	NBR and PUR	brass, nickel-plated	G 1/4	900	2 - 8	460	2	24/DC	131 421
									24/50-60	131 422
									110/50-60	131 423
									230/50-60	131 424

¹⁾ If the connectors are from stainless steel, the mounting screws will also be from stainless steel²⁾ Flow rate: Q_{n0} value air [l/min]: Measured at +20°C, 6 bar pressure at valve inlet, 1 bar pressure difference³⁾ Pressure values [bar]: Gauge pressures with respect to the prevailing atmospheric pressure

Cable plug Type 2508 acc. DIN 175301-803 Form A:

(see also datasheet type 2508)

Circuitry	Voltage	Item no.
For standard version 6518/19 fixing screw in steel (zinc plated and chromatised)		
without circuit (standard)	0 - 250 V	008 376

Ordering chart – accessory zum Anbau von Positioner

Description	Item no.
Universal adapter for wave	787 338
Universal assembly bridge	770 294

i Further versions on request

- >** **Additional**
Electrical-mechanical position feedback
Contactless position feedback

To find your nearest Bürkert facility, click on the orange box →

www.burkert.com